

(No Model.)

2 Sheets—Sheet 1.

C. A. KING.
MACHINE FOR TURNING GUN BARRELS.
No. 287,548. Patented Oct. 30, 1883.

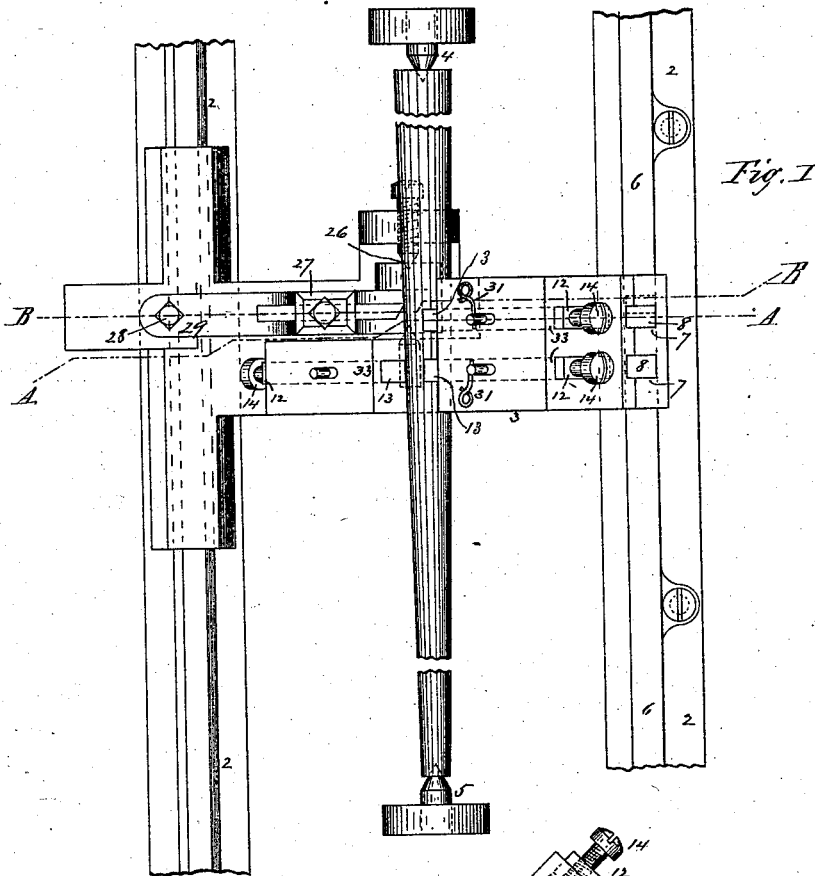

Fig. I

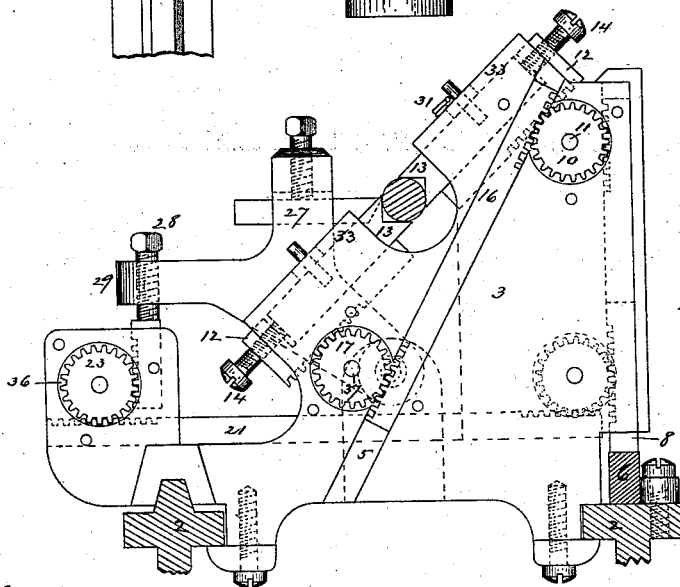

Fig. IV

Witnesses.

Charles H. Wood

George V. Curtis.

Inventor.

Charles A. King.
By J. A. Curtis,
his atty.

(No Model.)

2 Sheets—Sheet 2.

C. A. KING.

MACHINE FOR TURNING GUN BARRELS.

No. 287,548.

Patented Oct. 30, 1883.

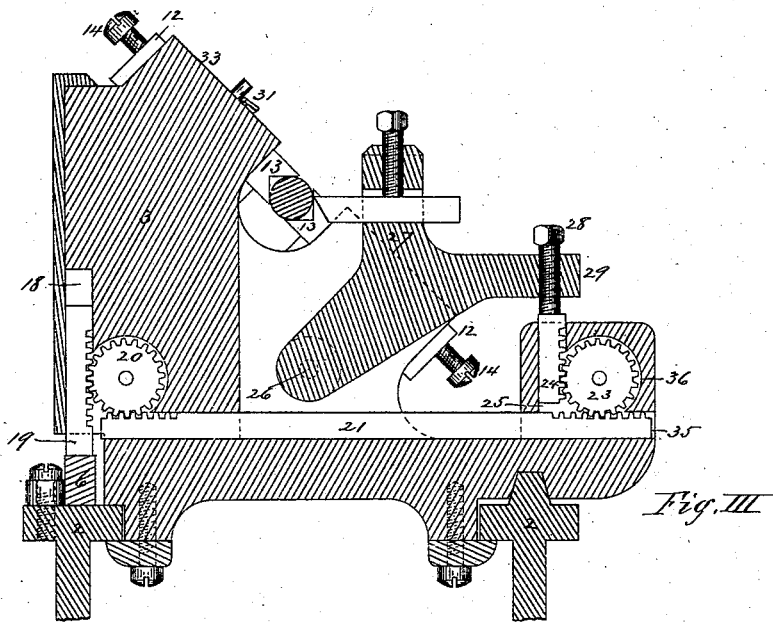

Fig. III

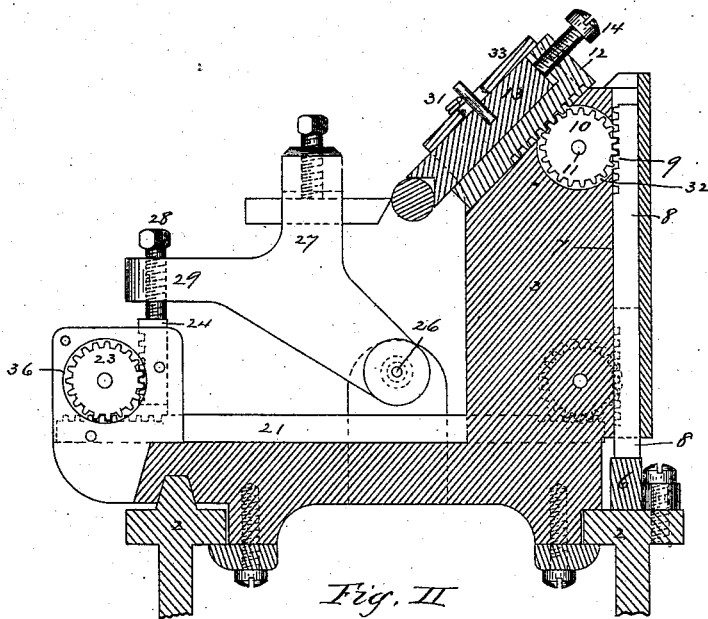

Fig. II

Witnesses.

Chas. H. Wood.

George V. Curtis.

Inventor.

Charles A. King,
By T. Alcutis,
his atty.

UNITED STATES PATENT OFFICE.

CHARLES A. KING, OF MERIDEN, CONNECTICUT.

MACHINE FOR TURNING GUN-BARRELS.

SPECIFICATION forming part of Letters Patent No. 287,548, dated October 30, 1883.

Application filed February 8, 1883. (No model.)

To all whom it may concern:

Be it known that I, CHARLES A. KING, of Meriden, in the county of New Haven and State of Connecticut, have invented a new and useful Improvement in Machines for Turning Gun-Barrels and other Articles of Irregular Form, of which the following is a specification.

The object of my invention is to provide a machine for turning barrels and other articles, in which the cutting-tool and the movable rests which support the barrel or other article near the cutting-tool, and which move with the latter, are all operated by a single former or guide; and I accomplish this by the mechanism substantially as hereinafter described, and illustrated in the accompanying drawings, in which—

Figure I is a plan view of a machine for turning gun-barrels, made according to my invention. Fig. II is a vertical transverse section at line A of Fig. I, showing a single back rest operated by the former or guide, and the toothed mechanism connected therewith. Fig. III is a vertical transverse section at line B of Fig. I, showing the former or guide and the toothed mechanism connected therewith, by which the cutting-tool is automatically operated to give the desired form to the barrel; and Fig. IV is an end view, showing the toothed mechanism by which a front and back rest are both actuated in unison by the same guide or former.

In the drawings, 2 represents the supporting-bed of the machine, provided with ordinary ways, upon and along which a carriage, 3, is adapted to be moved by means of the ordinary well-known feed mechanism connected with the driving-gear, as in the usual construction of similar lathes. This bed is also provided with the common head-block and tail-block, containing, respectively, the centers 4 and 5, between which the barrel is secured to be turned. A former or guide, 6, is secured to the top of this bed, at the rear side, whose upper surface has a horizontal profile or form corresponding to the taper which it is desired to turn the barrel, and the latter is secured in the lathe or machine to be turned, with its largest end toward the same end of the machine as the depressions in the said former or guide. A vertical recess, 7, is made in the rear side of the carriage, directly

above the former or guide, into which is fitted to slide freely a plunger, 8, having teeth or recesses, as 9, made on its rear side, at its upper part. Suitable guideways are made in the upper part of the carriage, in which a carrier, 12, is fitted to slide freely, said carrier having an upwardly-projecting flange or shoulder, 30, through which is turned an adjusting-screw, 14, and a rest, 13, is supported upon this carrier, being held upward against the adjusting-screw 14, preferably by a spring, as at 31. A recess, 32, is made in the upper part of the carriage 3, in which is secured a toothed wheel, 10, to turn or revolve on an axle, 11, and whose teeth engage with teeth or recesses made on the inner side of the plunger 8, and similar teeth or recesses are made on the inner side of the carrier 12, to also engage with the teeth of said wheel.

If it is desired to use two back rests 13, they may be placed side by side in guideways made on the top of the carriage, and two plungers 8 be placed side by side in suitable recesses, 9, in the back part of the carriage, with their lower ends at the point of bearing upon the former or guide 6, at the same distance apart as the ends of the two rests, which bear against the barrel while the latter is being turned. In this case the two toothed wheels 10 may be arranged to turn on the same shaft or axle 11.

If it should be desired to use a front rest in connection with a back rest, one opposite the other, to support the barrel on opposite sides while being turned, as it is necessary to do in turning thin delicate barrels for shotguns, it may be done, and both said rests be operated by one and the same plunger. In this case I make a recess, as 15, in the carriage to receive a bar, 16, having teeth or recesses on its lower edge, at the upper end, to engage with the toothed wheel 10, and having teeth or recesses on its upper edge, at the lower end, to engage with the teeth of the wheel 17, arranged to turn on the shaft or axle 37, secured in the carriage. The teeth of this wheel 17 also engage with a toothed or recessed carrier 12, supporting a front rest 13, adapted to slide in guideways 33, but in a reversed position to the upper carrier and back rest, so that the barrel, when secured in the machine to be turned, is in a position between the said front and back

rests 13, to be supported thereby on two opposite sides, and both these rests are directly opposite the plunger 8. A vertical recess, 18, is made in the rear side of the carriage, to receive a plunger, 19, having teeth made on its rear side to engage with the teeth of a wheel, 20, adapted to revolve on an axle secured in the carriage, and the teeth of this wheel also engage with teeth made on the upper side, and at the end of a horizontal bar, 21, adapted to slide lengthwise in a recess, 35, made transversely across the carriage, in its lowest part, and having teeth or recesses on its upper side, at the other end, which engage with a toothed wheel, 23, secured to revolve on its axle in a recess at 36, in the front part of the carriage. A bar, 24, whose teeth engage with those of the wheel 23, is operated vertically in a recess, 25, by the movement of said wheel, to actuate the tool-holder 27, which is hung at its axis 26, either between centers or upon a rock-shaft. An adjusting-screw, 28, is turned through a threaded hole in the projecting arm 29 of the tool-holder, and rests upon the vertical bar 24, for the purpose of adjusting the tool placed in the holder in its relative position with the barrel being turned.

The former or guide 6 is secured to the bed in a position parallel with that of the barrel when secured in the machine to be turned, and its upper face is made of the exact form as the horizontal profile of the finished barrel, as before explained, and of course the highest end of the former or guide is opposite the smaller end of the barrel when the latter is being turned, and the lowest part of the upper face of the former or guide is opposite the larger part of the barrel.

The machine being set in motion, with the barrel secured therein, and the carriage 3 and the cutting-tool in a position to commence turning at the smaller end of the barrel, the carriage is automatically moved along the ways and the cutting-tool is slightly in advance of the first back rest, 13. As the lower end of the plunger 19 moves along on the former or guide 6, exactly opposite the cutting-tool, said plunger, as it is raised or depressed by contact with the upper face of the former or guide, moves the toothed wheel 20, the bar 21, the toothed wheel 23, the vertical bar 24, and the tool-holder and cutting-tool to a corresponding degree, and thus governs the form given to the exterior of the barrel by the cutting-tool. As the first back rest closely follows the cutting-tool along the barrel and is nearly opposite said tool, the lower end of its plunger moves along the upper face of the same former or guide, and by its vertical movement actuates the toothed wheel 10 and the carrier 12 and the back rest 13, and as the latter may first be adjusted by the screw 14 to bear against the barrel to just the desired degree to support the latter, precisely the same degree of support will be given to the barrel or other article being turned during the whole operation and throughout its entire length

through the medium of the plunger 8, toothed wheel 10, and carrier 12. If two or more back rests 13 are used, each is operated by a duplicate carrier 12, toothed wheel 10, and plunger 8. When a front rest is used with and opposite a back rest, the same toothed wheel 10 actuates the toothed or recessed carrier 12, and also actuates the sliding bar 16, wheel 17, and the lower toothed carrier 12, which carries the front rest 13, moving the latter upward against the barrel by the same movement of the plunger 8, which moves the upper back rest downward against the barrel to give the latter the same degree of support on its opposite sides. When once the rests 13 have been adjusted to the desired amount of bearing against the barrel or other article while being turned, this precise amount of bearing will be maintained during the whole operation without the least variation, as all the plungers occupy the same relative positions on the same former or guide 6 as the cutting-tool and rests occupy along the barrel, and these positions remain constant.

It is evident that inasmuch as the movement of the toothed wheels, toothed or recessed bars and the carriers 12 is very slight very few teeth would be required on the wheels 10, 20, and 23, so that in practice they might be merely pivoted arms or pinions, each engaging in one or more recesses in the bars and plungers to receive and give the desired movement. For that reason I prefer to denominate the wheels 10, 20, and 23 the "pinions" or "levers," as they act as levers to engage with the toothed or recessed bars to give the desired relative movement to the cutting-tool and the supporting-rests.

It is evident that instead of making recesses in the carriage to receive the toothed mechanism, the latter may be placed on the outside of the carriage, with suitable guide-pins or bearings secured thereto to hold the said mechanism in place.

Having thus described my invention, what I claim as new is—

1. In a machine for turning gun-barrels and other articles, a stationary former or guide secured to the bed of the machine, in combination with a carriage movable along said bed, a movable tool-holder attached thereto, a toothed or recessed bar abutting against said tool-holder, a toothed or recessed slide movable on said carriage, and having a bearing against said former or guide, and toothed mechanism engaging with said slide and said bar, whereby the movement of said slide along the former or guide will actuate the tool-holder and cutting-tool secured therein, to give form to the barrel being turned, substantially as described.

2. In a machine for turning gun-barrels and other articles, a stationary former or guide secured to the bed of the machine, in combination with a carriage movable along said bed, a carrier movable thereon and supporting a movable rest, a toothed or recessed slide mov-

able on said carriage, and having a bearing against said former or guide, and toothed mechanism engaging with said slide and with said carrier, whereby the movement of said slide along said former or guide will actuate said carrier and rest, substantially as described.

3. In a machine for turning gun-barrels and other articles, a single stationary former or guide secured to the bed of the machine, a carriage movable along said bed, a movable tool-holder attached thereto, a toothed or recessed bar abutting against said tool-holder, a toothed or recessed slide movable on said carriage, and having a bearing against said former or guide, toothed mechanism engaging with said slide and said bar, in combination with a carrier movable on said carriage and supporting a movable rest, and toothed mechanism engaging with said slide and with said carrier, whereby the said tool-holder and said rest are operated in unison in forming and supporting the barrel by the same former or guide, substantially as described.

4. In a machine for turning gun-barrels and other articles, a carriage provided with a toothed or recessed carrier having a projec-

tion or flange, a rest adapted to move in guideways, and supported upon said carrier, and an adjusting-screw turned through the projection or flange of said carrier for adjusting the pressure of the rest against the barrel being turned, substantially as described.

5. In a machine for turning gun-barrels and other articles, a single stationary former or guide secured to the bed of the machine, a carriage movable along said bed, a back rest and supporting-carrier adapted to move in guideways on the carriage, a front rest and carrier adapted to move in guideways, a toothed or recessed slide having a bearing against said former or guide, in combination with toothed mechanism engaging with said slide and with the front and back rest carriers, whereby said front and back rests for supporting the barrel on opposite sides are both operated in unison by the movement of a single slide along the said former or guide, substantially as described.

CHARLES A. KING.

Witnesses:

C. E. STOCKDER, Jr.,
RALPH A. PALMER.